



## APPLICATION: Advanced Drinking Water Filtration

The 3M™ Full Flow Drinking Water System provides advanced filtration for cleaner, better tasting water by reducing common contaminants. It fits easily under your kitchen sink and operates through your existing faucet.

The advanced system is quick and easy to install. The replacement filter is easy to change too – twist on, twist off, no mess. This system helps address a number of contaminants that may be found in your water including chlorine taste and odor, sediment, lead and cysts.



**MODEL: 3MDW201**

## PRODUCT BENEFITS:

- Reduces chlorine taste and odor, sediment, lead and cysts.
- Installs under the sink for drinking and cooking water use.
- Designed with built-in shut off valve – no need to shut off water for filter change.
- Simple yet effective pressure relief valve reduces water release during filter changes.
- Combines effectiveness of carbon filtration with a 0.2 nominal micron pharmaceutical-grade nylon membrane filter.
- 3/8” Quick Connect inlet and outlet head fittings allow ease of installation.
- Pre-filter wrap reduces sediment and other particulate matter while helping protect the carbon media.

## PRODUCT SPECIFICATIONS:

Model/Part Number	Reduction Claims	Dimensions (Ht. x Dia.)	Approx. Weight	Service Flow Rate	Temperature Range	Pressure Range	Capacity	Replacement Filter
3MDW201	Sediment, Chlorine Taste and Odor, Lead and Cysts*	16.25" x 4.4" (41.3 cm x 11.3 cm)	4.8 lbs (2.2 kg)	2.5 gpm (9.5 lpm)	40 - 100°F (4.4 - 37.8°C)	25 - 125 psi (172 - 862 kPa)	6,000 gallons (22,712 liters)	3MDW211

\* See Performance Data Sheet for details and additional reduction claims

To obtain additional information please call our Customer Care team at 855-3M-WATER or visit our website at [www.3MWater.com](http://www.3MWater.com)

## INSTALLATION DIFFICULTY



Skills Needed: (Please refer to installation difficult chart on website for additional information)

- Novice plumbing skills required

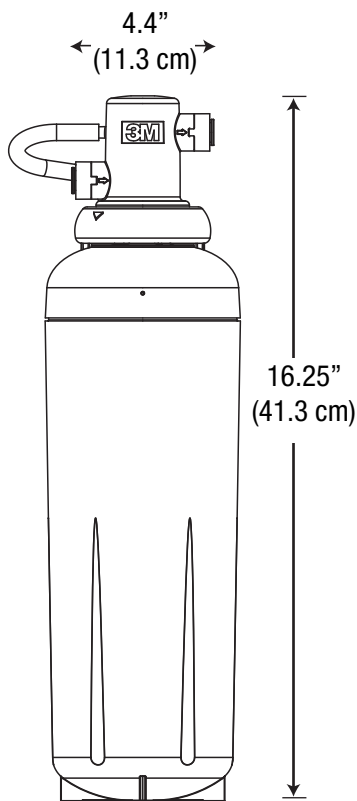

## SPECIFICATIONS

- Includes a head assembly and a single replacement filter.
- Inlet and outlet plumbing connections are 3/8" Quick Connect.
- System maximum operating pressure of 125 psi (862 kPa) and operating temperature of 100°F (37.8°C).
- Replacement filters incorporate carbon block media.
- System is NSF Standards 42 and 53 certified.
- Replacement filters are sanitary in design, requiring no contact with the filter media during filter change-out.

## IMPORTANT

**⚠ WARNING: To reduce the risk associated with the ingestion of contaminants:**

- **Do not use with water that is microbiologically unsafe or of unknown quality without adequate disinfection before or after the system.** Systems certified for cyst reduction may be used on disinfected water that may contain filterable cysts.

EPA Establishment # 070595-CT-001

**CAUTION: To reduce the risk associated with property damage due to water leakage:**

- **Read and follow** Use Instructions before installation and use of this system.
- Installation and use **MUST** comply with all state and local plumbing codes.
- **Do not install** if water pressure exceeds 125 psi (862 kPa). If your water pressure exceeds 80 psi (552 kPa), you must install a pressure limiting valve. Contact a plumbing professional if you are uncertain how to check your water pressure.
- The disposable replacement filter **MUST** be replaced every 12 months, at the rated capacity or sooner if a noticeable reduction in flow rate occurs.

3M recommends regularly scheduled maintenance and replacement of the filters in order for the product to perform as advertised/sold. 3M shall not be liable for system failures due to improper maintenance.

## LIMITED WARRANTY

3M Purification Inc. warrants this Product will be free from defects in material and manufacture for the following periods from the date of purchase. Ten (10) year for the Product, except for the replacement filter cartridge and membrane, which are warranted for one (1) year. This warranty does not cover failures resulting from abuse, misuse, alteration or damage not caused by 3M or failure to follow installation and use instructions. No warranty is given as to the service life of any filter cartridge or membrane as it will vary with local water conditions and water consumption. **3M MAKES NO OTHER WARRANTIES OR CONDITIONS, EXPRESS OR IMPLIED, INCLUDING, BUT NOT LIMITED TO, ANY IMPLIED WARRANTY OR CONDITION OF MERCHANTABILITY OR FITNESS FOR A PARTICULAR PURPOSE OR ANY IMPLIED WARRANTY OR CONDITION ARISING OUT OF A COURSE OF DEALING, CUSTOMER OR USAGE OF TRADE.** If the Product fails to satisfy this Limited Warranty during the warranty period, 3M will replace the Product or refund your Product purchase price. This warranty does not cover labor. **The remedy stated in this paragraph is Customer's sole remedy and 3M's exclusive obligation. For additional information, see the entire Limited Warranty located in the product Installation and Operating Instruction Manual.**

**Limitation of Liability.** 3M will not be liable for any loss or damage arising from this 3M product, whether direct, indirect, special, incidental, or consequential, regardless of the legal theory asserted, including warranty, contract, negligence or strict liability. Some states and countries do not allow the exclusion or limitation of incidental or consequential damages, so the above limitation or exclusion may not apply to you.